

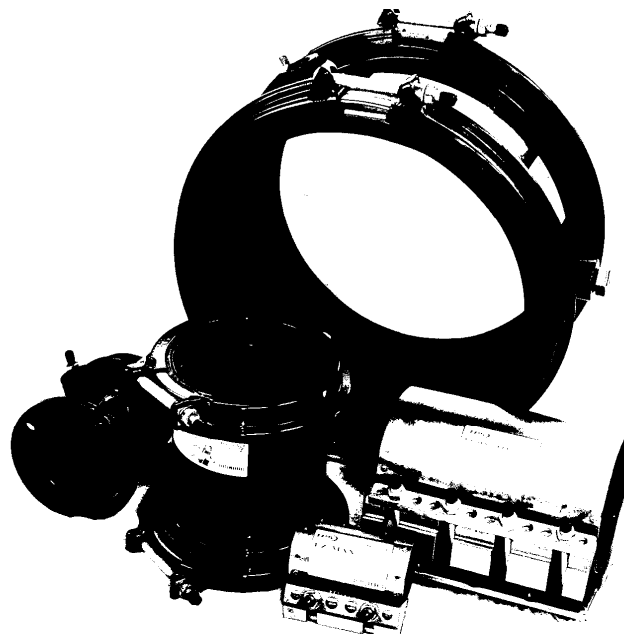

Total Piping Solutions, Inc.

● ● ● | **General Piping Installation  
Guidelines Including Information  
on Angular Deflection, Offset and  
Displaced Pipe, Pipe Tolerances,  
Anchoring, and Preparation of  
Pipe for Installation of  
Couplings**

- Total Piping Solutions, Inc.—A supplier of Quality Products for the joining and repair of pipe systems
- Piping Products for Municipal Water Supply
- Piping Products for Waste Water
- Piping Products for Industry
- Hymax®Couplings, Flanged Adaptors, EZ-MAX®Plus Stainless Steel Repair Clamps, Compression Fittings, Service Saddles and Tapping Sleeves



Date: 08/01/06



## Provisions for Pipe Displacement

### Shear from Lateral Displacement due to Settling, and Thermal Expansion and Contraction

When ever there is possibility for differential settlement between a structure such as a tank, building, foundation, vault etc....and the pipeline, provisions must be made to compensate for lateral displacement.

Single couplings accommodate very little lateral displacement because the coupling is placed in a shear condition.

Couplings should always be used in pairs when they are used to provide for parallel offset or lateral displacement due to settlement of pipe or structures.

In order to achieve a condition of lateral displacement without damage to either of the couplings , structure or pipe, the design must allow for angular deflection. Angular deflection is attained by using a spool piece or section of pipe between two couplings. The two couplings with the spool piece will act as a universal joint, allowing for lateral movement in any direction. Since the displacement can be made in any direction, the allowable movement in any direction can be twice the displacement.

The length of the spool piece will help determine the amount of displacement for a giving deflection. Calculation of the length of the spool piece can be determined per the following formula:

$X = Y / \text{Sine of the Maximum Allowable Coupling Angle of Deflection}$

(X = length of spool piece and Y = Lateral displacement)

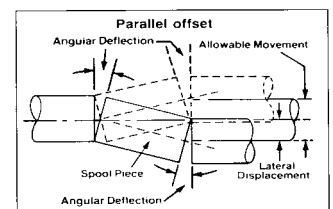
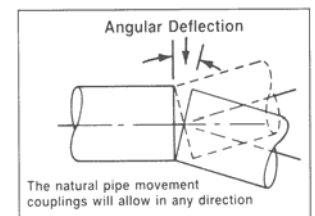
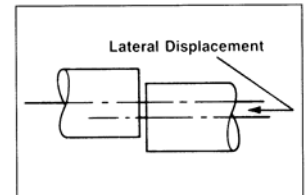

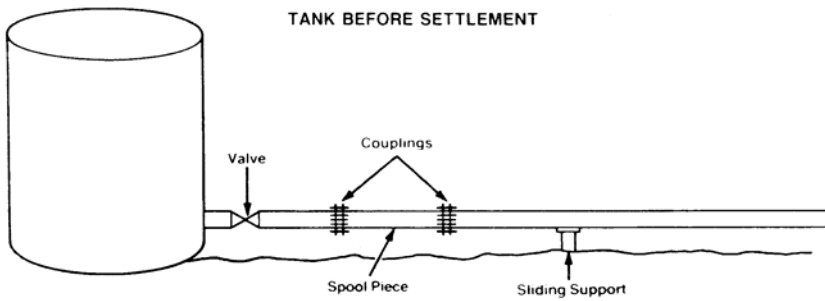

Typical Tank Installation

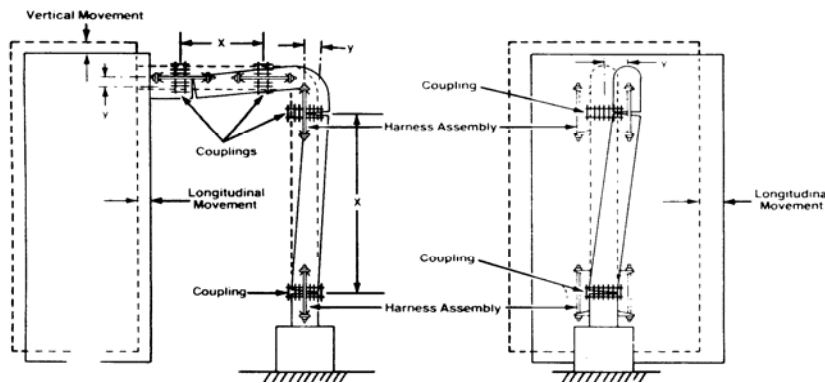
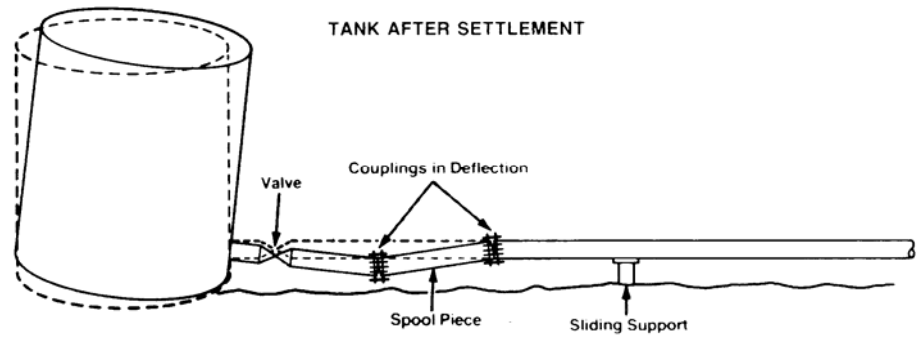

Typical Riser Installation

Couplings may be used to accommodate thermal expansion and contraction. The couplings will help to relieve bending stresses as pipe components enter a building or other structure.

Two couplings combined with a spool piece will help compensate for the settlement between a pipeline and a tank.

Two couplings and a spool will help movement of pipe risers in any direction.



## **Pipe Tolerance, Preparation of Pipe Ends, Sealing Surfaces, Pipe Ends and Coatings**

**Pipe Tolerance**—The following are suggested tolerances for use of Hymax® Wide Range Couplings by Total Piping Solutions, Inc. and KI Ltd.

**Sealing Surface for Steel, Ductile, PVC, P.E. or other Pipe Materials**– The pipe ends shall be sufficiently free from flat spots, indentations, projections, rust, scale and pits for a distance of 8-12 inches from the end of the pipe. This allows for the gasket to seal against a smooth surface to make a leak-free joint.

**Pipe Ends**—All pipe ends shall be furnished with a smooth, round end, suitable for mating with the gasket of a bolted compression coupling. Pipe ends must be in compliance with AWWA (American Water Works Association) specifications which govern most water pipe tolerances. Maximum outside pipe diameters shall permit the passage of the coupling past the pipe end for a distance of 8-12 inches. All pipe diameters shall be determined by circumferentially measuring the pipe with an all steel pipe diameter tape or O.D. Tape.

If the cut end of the pipe is out of round, a pipe condition more likely to occur in diameters greater than 12 inches, AWWA specified pipe tolerances per AWWA C219-01 must be maintained for proper seating of the gasket. (Maximum variation or tolerance shall not exceed .06" from 2 to 16 inches in diameter and .08" from 16 to 24 inches in diameter). To facilitate proper assembly and gasket seating, the pipe end may need to be rounded through the use of jacks, wedges, shims or other means. The pipe end may be temporarily or permanently rounded through various methods. Roundness of pipe may be measured by making diametric measurements at several points across the pipe end or through the use of a "no-go" ring gauge. When using a ring gauge, the gauge must pass across the first 10 to 12 inches from the plain end of the pipe. Ring gauges should have a 1/16" bore larger than the o.d. of the pipe.

**Pipe Coatings**—All pipe coatings should be strong enough to resist the sealing pressure of the coupling gasket. Porous coatings that allow line content to penetrate the coating must be removed up to a distance of 8 to 12 inches from the end of the pipe. Removal of the coating will allow for the coupling to seal against an impenetrable surface, providing for maximum sealing conditions.



## Methods to Support and Anchor Coupled Pipe Lines

Under internal pressure, water distribution pipelines may develop unbalanced forces where there are changes of size or direction of the line. These forces may result in the movement of the pipe. Since bolted sleeve-type couplings are un-restrained, they do not provide protection against pull out of the pipe ends. Consequently, the pipe must be suitably anchored, harnessed or restrained to prevent excessive pipe movement. Couplings are capable of absorbing up to 3/8" axial pipe movement, which is equal to the expansion and contraction of a 40 ft. section of carbon steel pipe experiencing a 120° F change of temperature. The amount of movement across any coupling is a function of the gaskets ability to accommodate the axial motion of the line. The following illustrations show how mechanically coupled pipe lines may be supported and anchored. All anchors and supports should be designed to carry the weight of the pipe and the content of the line, and have the capability to prevent total pipe movement from passing across any single coupling.

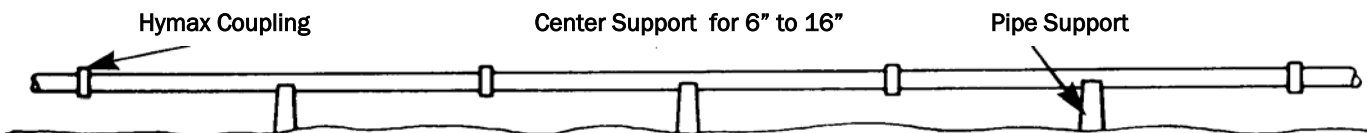
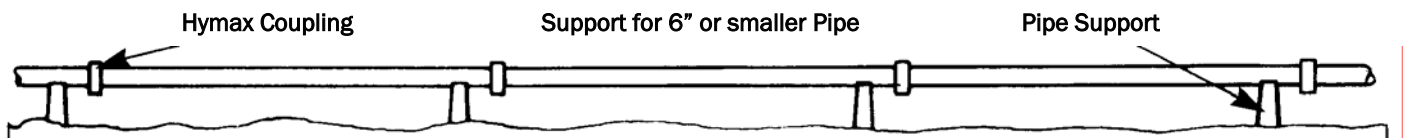

Support for Pipes in any size of 40 ft lengths and any pressure. Each length is to be tied to only ONE support to allow for expansion and contraction.

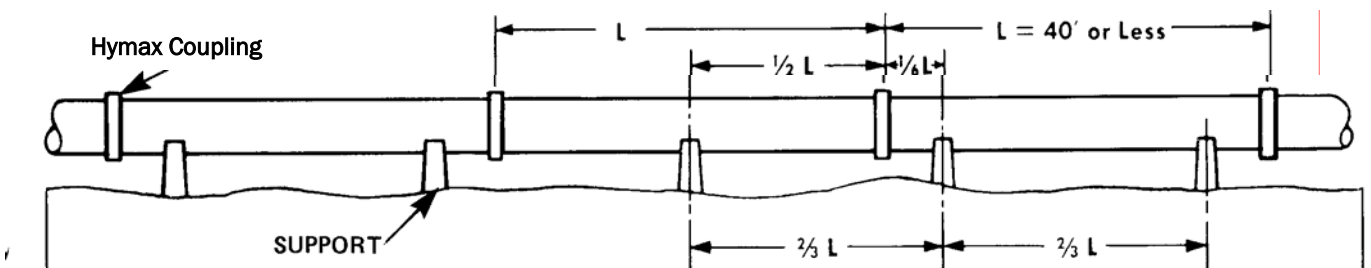

Note: Ring Girder and Sliding Saddle type supports may be used as alternate supports for steep grades and hilly terrain.



## Making Pipe Measurements

Making proper determination of the pipe diameter is crucial towards selection of the correct diameter pipe fitting.

There are several ways to determine the O.D. or outside diameter of the pipe.

The preferred method is to use an O.D. Tape Measure, specifically designed to wrap around the outside of the pipe. Pipe O.D. tapes are available from most pipe, fitting or coupling manufactures. (see figure 1)

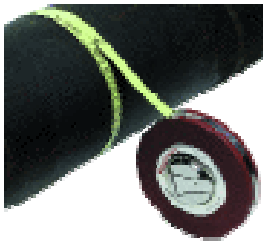

Figure 1

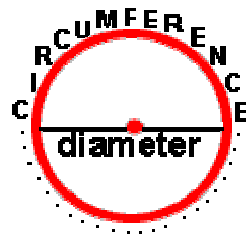

Figure 2

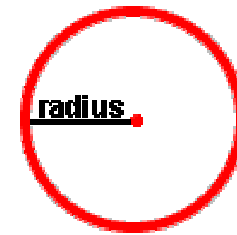

Figure 3

In the event an O.D. tape is not used, an approximate diameter may be determined if the radius is known, if the circumference can be measured or if the radius is given.

Diameter “D” can be determined as follows:

1. “D” Diameter = Radius “R” x 2

The radius of a circle is the distance from the center to any point on the circle (see figure 3)

2. “D” Diameter = Circumference ÷  $\pi$  (3.14)

The value of “ $\pi$ ” OR “Pi” is approximately 3.14. 3.14 is the ratio of the Circumference to the Diameter (see figure 2)

The chart on the following page represents various nominal pipe diameters. All information on the chart is based on the most recent information as supplied by the pipe manufacturers. Always check the pipe O.D. or circumference before ordering any pipe joining or repair products. All pipe O.D.’s are specified in inches on the chart. Total Piping Solutions, Inc. will be happy to assist you in the selection of products that best suite your requirements.



For More Information Call 1-716-372-0160

### Pipe Outer Diameter Chart

This chart is based on the most recent pipe standards and information supplied by pipe manufacturers. Always check the pipe O.D. or circumference before ordering pipe joining and repair products. Total Piping Solutions, Inc. is happy to help you choose the

Pipe Type	Nominal Pipe Size (inches)																				
	1/2	3/4	1	1 1/4	1 1/2	2	2 1/2	3	4	5	6	8	10	12	14	15	16	18	20	24	30
<i>Copper, Steel &amp; Plastic Pipe</i>																					
Copper Tubing (C.T.S.)	0.63	0.88	1.13	1.38	1.63	2.13	2.63	3.13	4.13	5.13	6.13										
Schedule 40 Steel Pipe	0.84	1.05	1.32	1.66	1.9	2.38	2.88	3.5	4.5	5.56	6.63	8.63	10.75	12.75	14		16	18	20	24	30
PVC-STD			1.32		1.9	2.38	2.88	3.5	4.5		6.63	8.63	10.75	12.75							
PVC-C.I. Size									4.8		6.9	9.05	11.1	13.2							
Polyethylene Pipe IPS		1.05	1.32	1.66	1.9	2.38		3.5	4.5	5.56	6.63	8.63	10.75	12.75	14		16	18	20	24	30
Polyethylene Pipe DI Size									4.8		6.9	9.05	11.1	13.2			17.4	19.5	21.6	25.8	
<i>Cast Iron Pipe</i>	1/2	3/4	1	1 1/4	1 1/2	2	2 1/2	3	4	5	6	8	10	12	14	15	16	18	20	24	30
Class 100-250 AWWA								3.96	4.8		6.9	9.05	11.1	13.2	15.3		17.4	19.5	21.6	25.8	32
Class A AWWA Pit Cast						2.5		3.8	4.8		6.9	9.05	11.1	13.2	15.3		17.4	19.5	21.6	25.8	31.74
Class B AWWA Pit Cast								3.96	5		7.1	9.05	11.1	13.2	15.3		17.4	19.5	21.6	25.8	32
Class C AWWA Pit Cast								3.96	5		7.1	9.3	11.4	13.5	15.65		17.8	19.92	22.06	26.32	32.4
Class D AWWA Pit Cast								3.96	5		7.1	9.3	11.4	13.5	15.65		17.8	19.92	22.06	26.32	32.74
<i>Class 100 Asbestos Cement Pipe</i>	1/2	3/4	1	1 1/4	1 1/2	2	2 1/2	3	4	5	6	8	10	12	14	15	16	18	20	24	30
Machined End								3.74	4.64		6.91	9.11	11.24	13.44	15.07		17.15	19.9	22.12	26.48	33.12
Fluid-Tite Rough Barrel								3.93	5.05		7.16	9.32	11.46	13.7	15.36		17.5				
Flintite M.E.								3.74	4.64		6.91	9.11	10.89	12.99	15.07		17.15	19.9	22.12	26.48	33.12
Flintite Rough Barrel								3.94	4.9		7.13	9.33	11.3	13.42	15.45		17.6				
Ring-Tite Rough Barrel								3.95	4.92		7.19	9.39	11.47	13.74	15.51		17.65	20.44	22.68	27.12	33.8
Permafex Rough Barrel									4.84		7.15	9.35	11.47	13.74	15.55		17.55				
Minimum Standard Rough Barrel									4.79		7.05	9.22	11.25	13.37	15.36		17.5	20.44	22.5	27.17	
Maximum Standard Rough Barrel									5.26		7.4	9.57	11.77	14.04	15.8		17.94	20.44	22.5	27.17	
<i>Class 150 Asbestos Cement Pipe</i>	1/2	3/4	1	1 1/4	1 1/2	2	2 1/2	3	4	5	6	8	10	12	14	15	16	18	20	24	30
Machined End								3.84	4.81		6.91	9.11	11.66	13.92	16.22		18.46	20.94	23.28	27.96	35
Fluid-Tite Rough Barrel								4.03	5.14		7.12	9.32	11.85	14.11	16.41		18.65				
Flintite Rough Barrel								4.04	5.01		7.13	9.33	11.88	14.14	16.48		18.72				
Ring-Tite Rough Barrel								4.13	5.07		7.17	9.37	11.92	14.18	16.48		18.72	21.3	23.64	28.32	35.42
Permafex Rough Barrel									5		7.2	9.4	11.92	14.2	16.5		18.75				
Minimum Standard Rough Barrel									4.97		7.07	9.27	11.82	14.08	16.38		18.62	21.2	23.54	28.22	
Maximum Standard Rough Barrel									5.32		7.37	9.62	12.12	14.38	16.73		18.97	21.2	23.54	28.22	
<i>Class 200 Asbestos Cement Pipe</i>	1/2	3/4	1	1 1/4	1 1/2	2	2 1/2	3	4	5	6	8	10	12	14	15	16	18	20	24	30
Machined End								3.84	4.81		6.91	9.11	11.66	13.92	16.22		18.46	22.18	24.66	29.62	37.06
Fluid-Tite Rough Barrel								4.18	5.32		7.36	9.46	11.88	14.11	16.44		18.74				
Flintite Rough Barrel								4.17	5.32		7.26	9.44	11.88	14.14	16.53		18.84				
Ring-Tite Rough Barrel								4.17	5.33		7.32	9.5	11.92	14.18	16.55		18.9	22.54	25.02	29.98	37.48
Permafex Rough Barrel									5.32		7.26	9.5	11.95	14.2	16.55		18.9				
Minimum Standard Rough Barrel									5.22		7.26	9.39	11.77	14.03	16.44		18.74				
Maximum Standard Rough Barrel									5.57		7.6	9.79	12.12	14.38	16.88		19.19				
<i>Sewer Pipe</i>	1/2	3/4	1	1 1/4	1 1/2	2	2 1/2	3	4	5	6	8	10	12	14	15	16	18	20	24	30
A/C Sewer Class 1500									4.81		6.92	9.02	11.12	13.22	15.3	16.34	17.38				
A/C Sewer Class 2400									4.87		6.98	9.04	11.16	13.26	15.36	16.42	17.46	19.54	21.66	25.78	
A/C Sewer Class 3300									5.05		7.14	9.22	11.36	13.5	15.46	16.66	17.72	19.82	21.88	26.1	32.34
A/C Sewer Class 4000													11.5	13.64	15.78	16.84	17.9	20.02	22.1	26.32	32.6
A/C Sewer Class 5000													11.7	13.86	16	17.06	18.14	20.36	22.32	26.6	32.9
Asbestos Cement ACME								4.62	6.66		8.96	11.05	13.15	15.23	16.11	17.31	19.39	32.45	25.67	32.13	
PVC Plastic SDR 35								4.22			6.28	8.4	10.5	12.5							
PVC Plastic SDR 41								4.22			6.28	8.16	10.2	12.24		15.3		18.7		24.8	
Cast Iron Soil Pipe (No Hub)								4.38			6.3	8.38									
Cast Iron Soil Pipe (Service Weight)								4.3			6.3	8.38	10.5	12.5							
Cast Iron Soil Pipe (Extra Heavy)								4.62			6.62	8.75	10.88	12.88							
Clay Minimum								5			7.19	9.25	11.5	13.75		17.19		20.65		27.5	34.38
Clay Maximum								5.38			7.56	9.75	12	14.31		17.81		21.44		28.5	35.63
Concrete (Average)								6			8	10.25	12.75	15.5		18.75		22		29	35.5
<i>Irrigation Pipe</i>	1/2	3/4	1	1 1/4	1 1/2	2	2 1/2	3	4	5	6	8	10	12	14	15	16	18	20	24	30
Asbestos Cement Irrigation Type 5								4.74			6.7	9.02	11.12	13.22							
Asbestos Cement Irrigation Type 15								4.86			6.81	9.04	11.16	13.26							
Asbestos Cement Irrigation Type 25								4.97			7.1	9.27	11.31	13.74							
Plastic Irrigation Pipe (PIP)								4.13			6.14	8.16	10.2	12.24		15.3		18.7	22.05	24.8	
Pipe Type	1/2	3/4	1	1 1/4	1 1/2	2	2 1/2	3	4	5	6	8	10	12	14	15	16	18	20	24	30
	Nominal Pipe Size (inches)																				

## **Total Piping Solutions, Inc.**

A complete provider of piping solutions for the water and sewer industries. Products range from Couplings, Flanged Adaptors and Repair Clamps to Service Saddles and Fabricated Stainless Steel Tapping Sleeves.

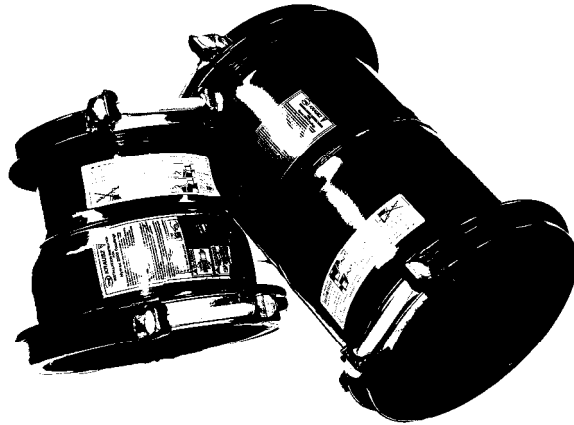

## **Total Piping Solutions, Inc.**

Total Piping Solutions, Inc.  
1760 Haskell Road  
P.O. Box 525  
Olean, New York 14760

Phone: 716-372-0160  
Fax: 716-372-1767  
Email: [sales@tps.us](mailto:sales@tps.us)  
<http://tps.us>

Every effort has been made to present accurate information, however, all information as provided in this brochure are presented as a guide only. Each application must be evaluated on its own, and should be reviewed by a qualified engineer to verify that all conditions including temperature, pressure and other performance criteria are applicable. Anyone making use of this information assumes all liabilities from such use.